

Die Maße

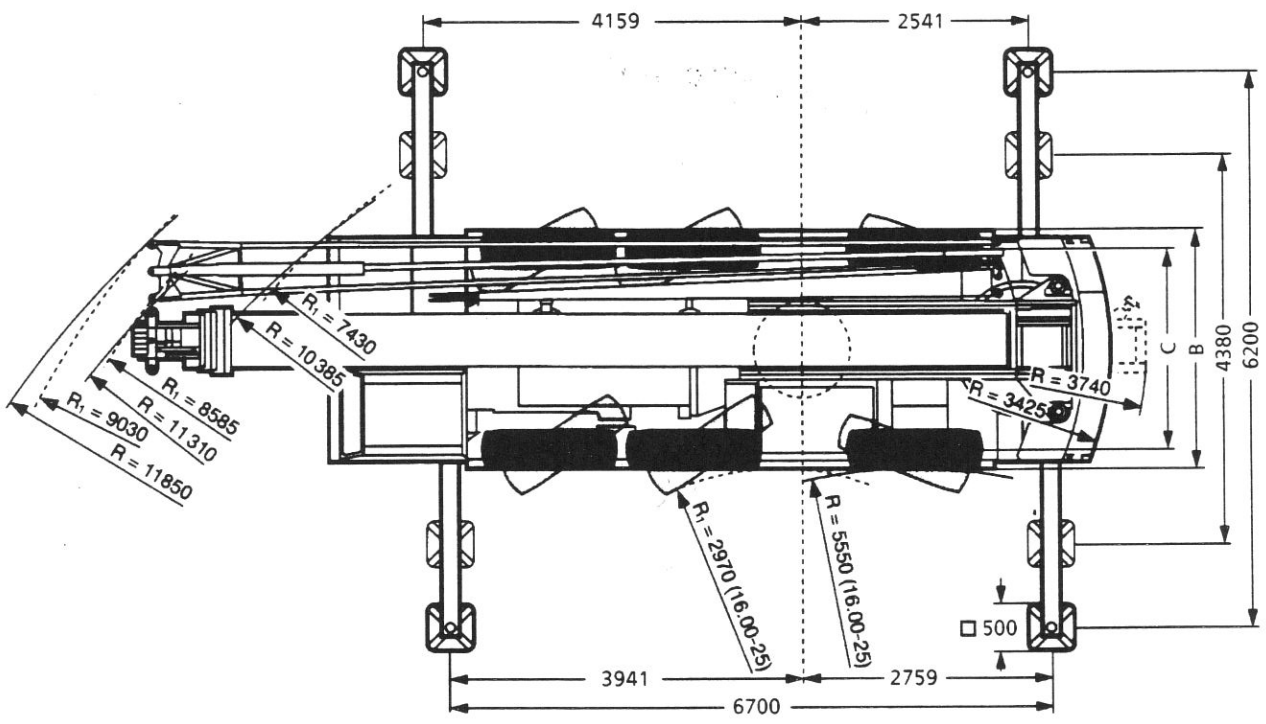
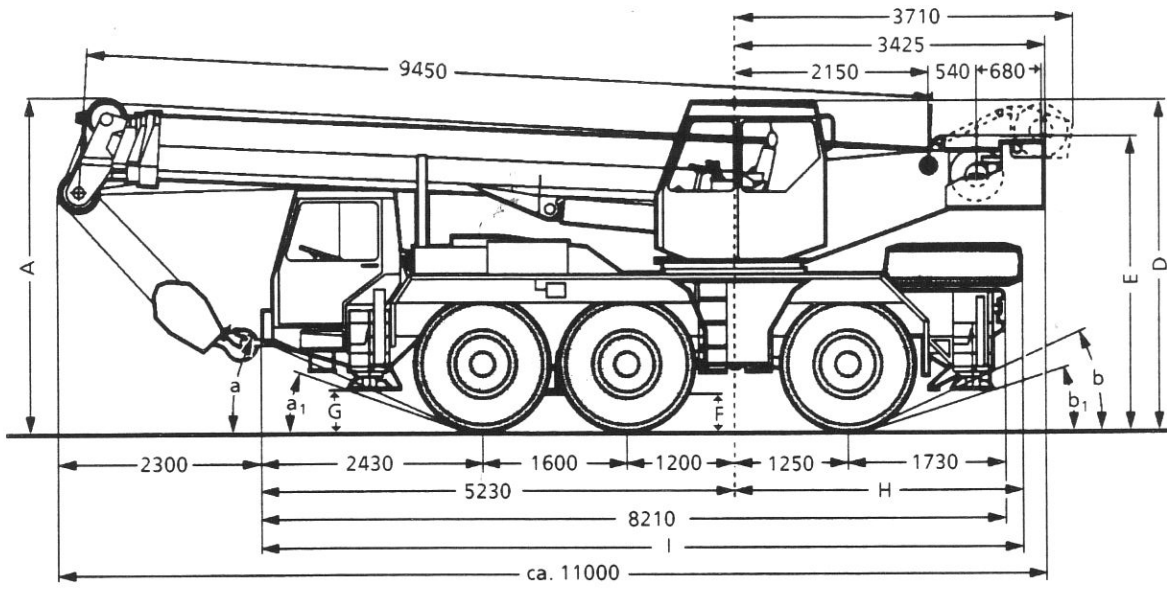

## Die Maße

Reifengröße	A	A 100 mm *	B	C	D	E **	F	G	H	I
14.00 R 25	3600	3500	2500	2113	3545	3025	280	410	3120	8350
16.00 R 25	3650	3550	2660	2225	3595	3075	330	460	3170	8400
20.5 R 25	3650	3550	2800	2253	3595	3075	330	460	3170	8400

\* abgesenkt

\*\* abgesenkt und ohne Kabinenoberteil

Reifengröße	a	a <sub>1</sub>	b	b <sub>1</sub>
14.00 R 25	22°	17°	22°	15°
16.00 R 25	25°	19°	25°	17°
20.5 R 25	25°	19°	25°	17°

